

# 3400W Solar Battery Charger Maximum Power Point Tracker

Operating Instructions  
Please read these instructions before use



This revolutionary maximum power point tracker solar charger was designed using the technology that won GSL Electronics the prestigious EDN Innovation Awards 08' and 09' and the Greentech Consensus Awards 09'. A simple, compact and low cost alternative to increase your bulk charge current by more than 20% over conventional solar regulators while significantly adding to your choice of panels and batteries.

The MPPT 60-2 is designed to automatically charge 12V, 24V and 48V sealed and vented lead acid batteries from silicon based pv panels such as monocrystalline, polycrystalline and thin film. It has a built in Load Low Voltage Disconnect configurable as a Dawn to Dusk switch. It can be connected to the MCM for remote control and full system parameter logging and display.

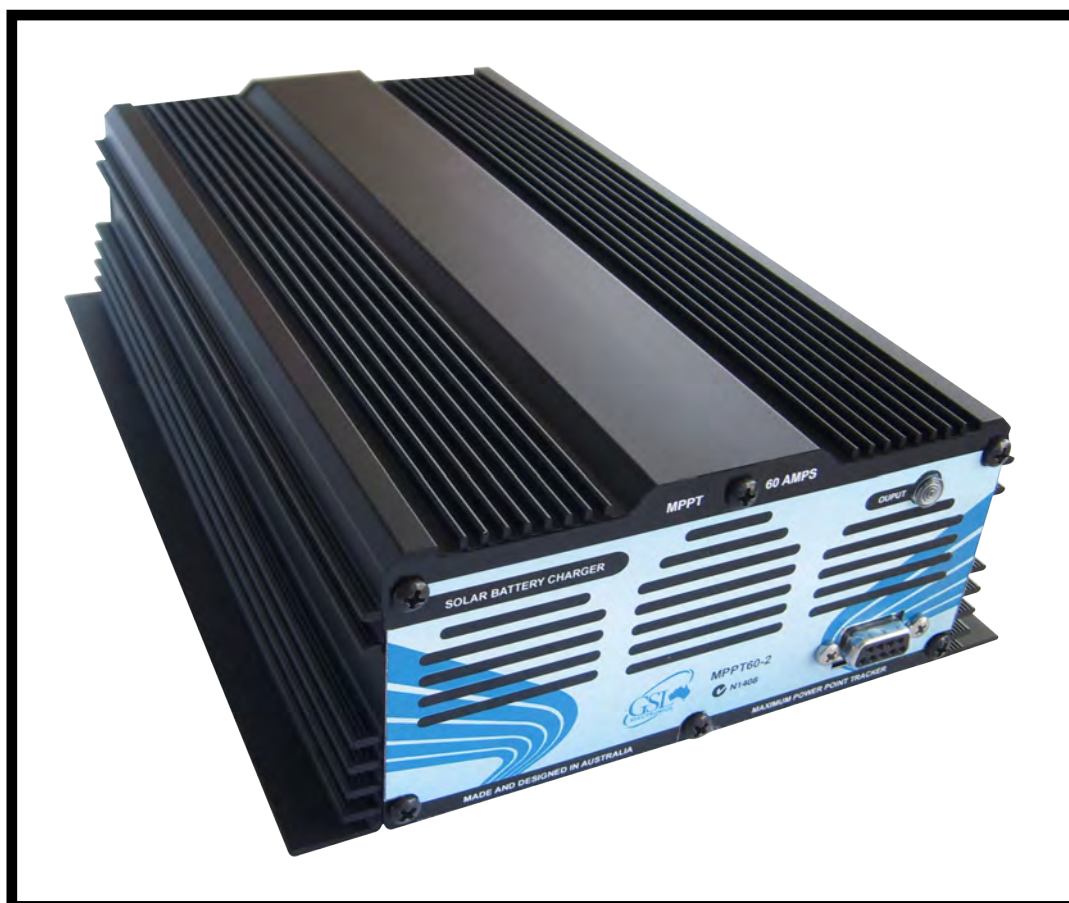

PATENT APPLIED FOR - 2010901565



<b>MPPT60-2 Specifications</b>	
Efficiency typical	96%
Input voltage	15V to 95V
Output voltage	<b>Float</b> 13.5V / 27V / 54V <b>Absorption - Vented LA Batteries</b> 14.5V / 29V / 58V <b>Sealed - LA Batteries</b> 14.2V / 28.4V / 56.8V
Output power	3400W / 60A MAX
Quiescent current	0.05A
Thermal protection	Multilevel Type
Dimensions (mm)	260 X 145 X 67mm
Indications	LED display – OUTPUT STATUS

**Important notes:**

- This equipment must be installed by qualified personnel only and incorrect wiring can cause fire, injury or death – GSL will accept no responsibility for MPPT misconnection or misuse.
- Use only sealed or vented 12V, 24V or 48V lead acid batteries and confirm the MPPT settings, charge voltages and currents are correct for your battery system – if in any doubt seek qualified advice!
- Use only panels with open circuit voltage below 95V.
- Use wires suitable for at least 40A, but if wire runs are over 3m then larger wires are recommended to limit voltage drop and losses.
- Install the unit in a dry place out of direct sunlight and away from flammable liquids or gases.
- Battery fuse ( BF ) is always required and must be located as close to the battery as possible, its sizing depends on the wire size and load ratings. Typically a 80A 60VDC fuse would do.
- The MPPT60-2 will efficiently charge 12V batteries from 12V, 24V or 48V panels, 24V batteries from 24V or 48V panels and 48V batteries from 48V panels
- The recommended lowest panel maximum power point voltages are 15V for 12V batteries, 30V for 24V batteries and 60V for 48V batteries.



**BASIC WIRING OPTIONS:**

**Permanent Load Connection**

**(Figure 1):**

Simplest wiring option where the load is permanently connected and the batteries are not protected from over discharge.

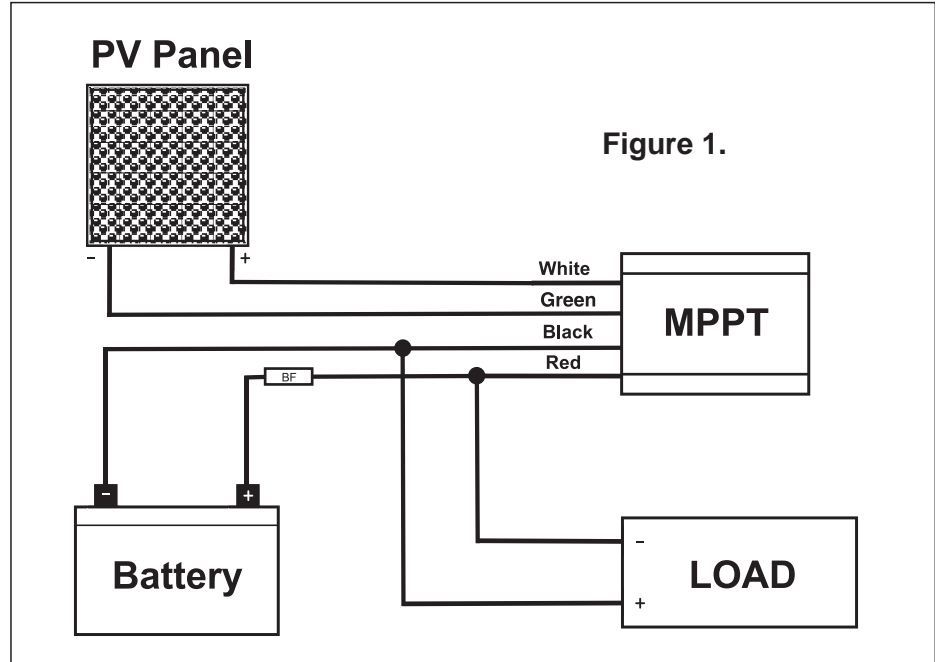

**Wiring With Low Voltage**

**Disconnect (Figure 2) :**

This option protects the battery from over discharge by disconnecting the load. The LVD option disconnects the load when the battery voltage drops below 0.85 of nominal voltage to protect the battery from damage. The load reconnects when the battery voltage exceeds 0.95 of nominal voltage. This feature will not trigger during short transients. LVD load is 60A continuous or 100A transient.

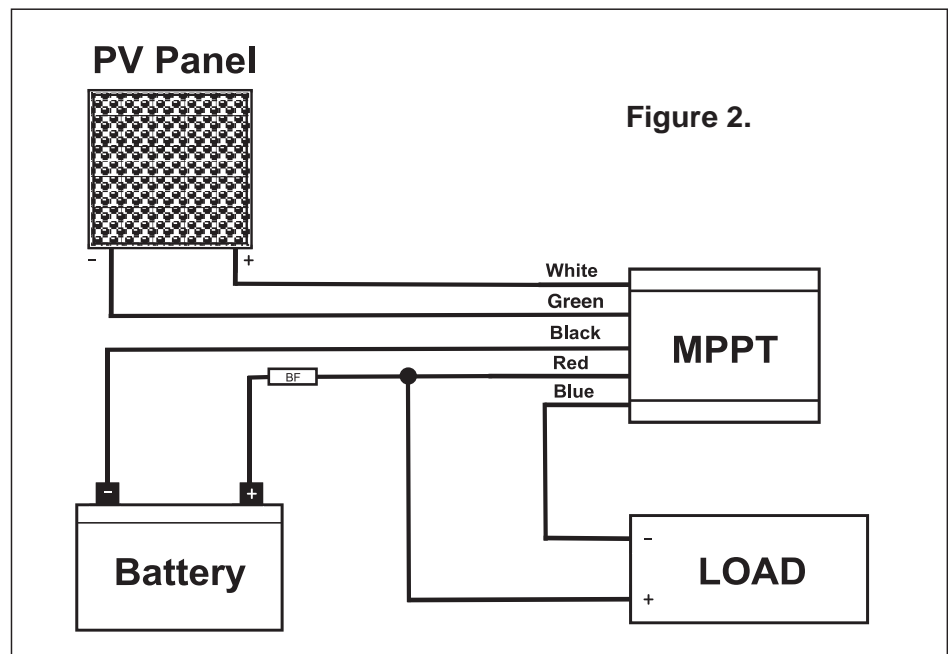

**Wiring With Critical And Non Critical Loads (Figure 3):**

Critical loads are generally light loads which are powered under any condition. Non critical loads are loads which can be disconnected to ensure maximum on time for critical loads as well as to extend the life expectancy and reliability of the system. The non critical load can be set up as LVD or Dawn to Dusk loads.

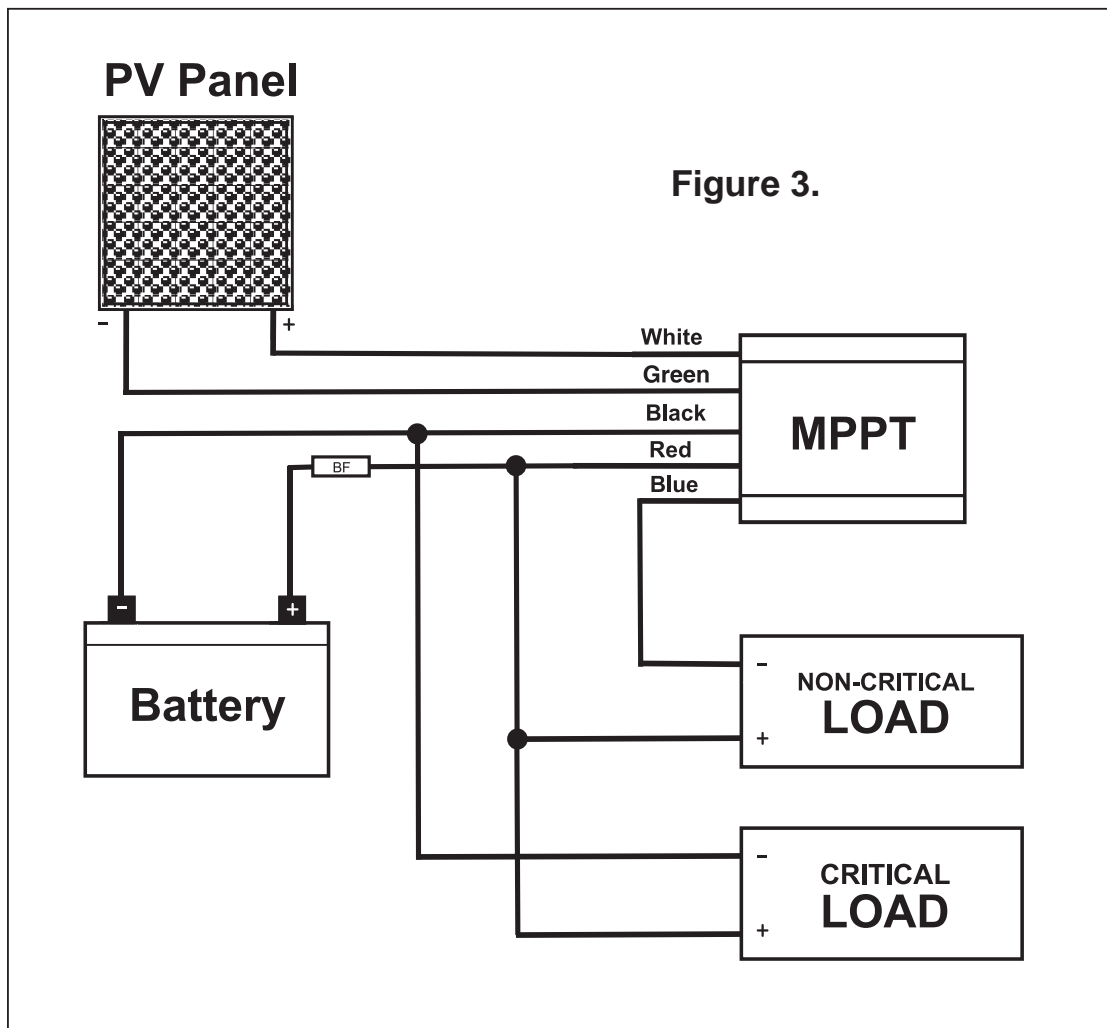

**Wiring with MCM option:**

Connecting the optional MCM to the MPPT will allow various system parameter display, output voltage and alarm settings and enable the programmable dawn to dusk or remote load control options. **For more details please refer to MCM Manual.**



**MPPT60-2 General Information:**

- Green LED On – Battery Ok.
- Green LED Flashing – Battery Low.
- This MPPT is designed to auto detect 12V, 24V or 48V battery systems and select a suitable charge regime.
- The MPPT 60-2 is shipped in a sealed battery setting which is the safest setting but if your batteries are vented then, **BEFORE** wiring the MPPT in, follow the **CHANGING BATTERY TYPE SETTING PROCEDURE.**
- The maximum absorption voltage is 14.5V, 29V or 58V and the float voltage is 13.5V, 27V or 54V for 12V, 24V or 48V batteries respectively.
- The absorption phase is entered following a low battery condition or dawn and is maintained until the battery demand falls below 2A.
- Custom float and absorption voltages and thresholds are possible but minimum orders apply.
- This MPPT has a built in multilevel over temperature protection to improve product reliability while maximising output power availability.
- The maximum continuous output power is 3400W in 48V systems, 1700W in 24V systems and 850W in 12V systems. The output current is limited to 60A.

**Note: This unit can be used to directly power (without a battery)  
a 12VDC motor or pump of up to 300W.**

### Changing Battery Type Setting Procedure

- 1.Ensure all the MPPT wires are disconnected.
  - 2.Remove 7 front panel screws and the front panel and slide out cover – see **Figure 4**.
  - 3.Locate connector J4 – see **Figure 4**.
  - 4.Shift link on J4 to vented position – see **Figure 5**.
  - 5.Slide back cover and fit in front panel carefully, insuring led fits properly into housing, and screw back the 7 mounting screws.
- The above procedure can be repeated to turn back to sealed mode – see **Figure 6**.

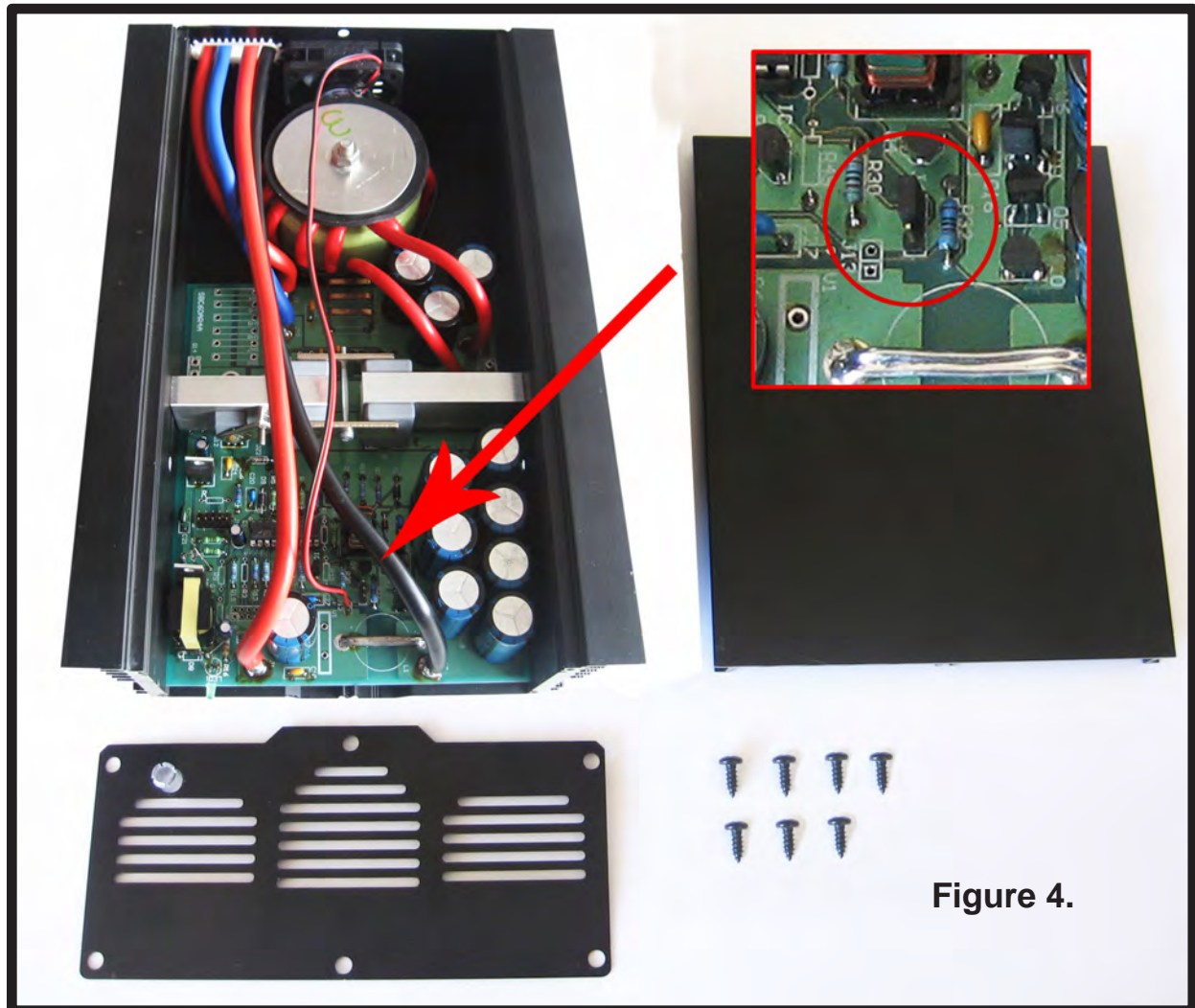

**Figure 4.**

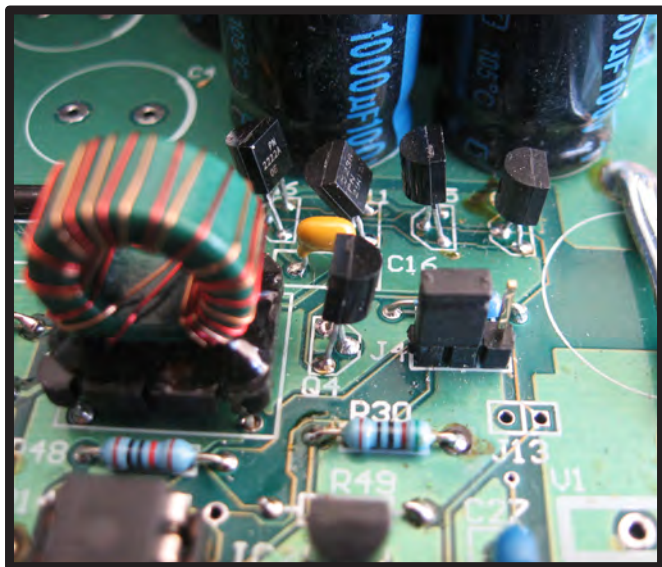

**Figure 5 (Above):** Vented Battery Setting

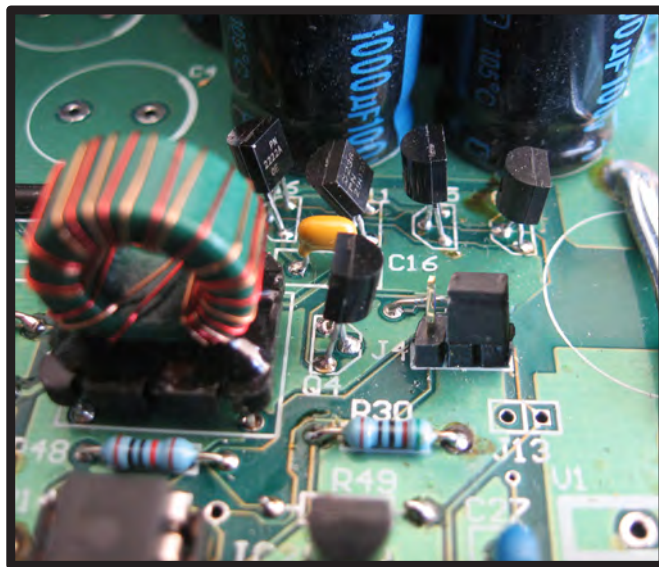

**Figure 6 (Above):** Sealed Battery Setting

#### MPPT FAQs

**Q: What is an MPPT?**

MPPT stands for Maximum Power Point Tracker and is a specialized converter designed to maintain the PV voltage at the level in which it delivers maximum power to the load or battery. The panel's nominal output power can only be obtained with the use of an MPPT.

**Q: What are the MPPTs advantages compared to standard solar regulators?**

1. About 20% higher current in a typical application which can be used for higher loads or longer run times or cutting PV system cost.
2. Suitable for lower cost non battery type PV since the MPPT can efficiently charge the batteries from relatively high voltage, say 12V batteries from 40V MPP panels.
3. Less interference and more accurate voltages during absorption and float.

**Q: What happens at low PV currents?**

The MPPT will outperform the conventional regulator above 3% of nominal panel power. Below 3%, about 10W in a 400W panel, the MPPT will have a slightly lower output current than a non MPPT.

**Q: Why are MPPT not more common in standalone solar systems?**

Until now and despite their overwhelming advantages MPPTs have not been commonly used in standalone solar systems because of cost. The new GSL MPPT specifically addresses this issue making economic sense in a wide range of solar systems.



**Q: What sort of batteries should I use?**

1. A deep cycle battery is a must due to the cyclical nature of the solar system with a recommended battery capacity of at least 360AH.
2. A larger battery will not only give longer run time during low light but also will be able to avoid available PV power being unstored such as when battery reaches the float stage.

**Q: How do PV temperatures affects charge current?**

Temperature increase brings down the PVs maximum power point voltage reducing the MPPTs current gain available. In principle at 25C it is possible to achieve 30% gain but at 40C, a more realistic average temperature, about 20% is still available.

**Q: What sorts of loads can I power with the MPPT60?**

1. The maximum bulk charge current with the MPPT60 on a 12V battery and 800W panel is approximately 60A, so you can expect about 200AH per day which means a 200W load for about 10 hours daily.
2. Following the same reasoning with a 24V 1600W panel the MPPT60 will supply a daily load of 400W for about 10 hours.
3. Following the same reasoning with a 48V 3200W panel the MPPT60 will supply a daily load of 800W for about 10 hours.

**Q: Is interference possible? and If so what do I do?**

GSL's MPPTs produce far less interference than conventional solar regulator during the absorption and float stages, that is during most of its operating time, and its designed to comply with local and international EMI standards however some interference is still possible. If interference occurs first try and reorient the aerial or move the sensitive equipment away from the MPPT wires. Ensure the MPPT chassis is grounded. Grounding a battery terminal may also help and finally you can try adding ferrite clamps.

*Warranty Conditions:* The product is warranted to be free from defects in materials and workmanship under normal use and service for a period of 24 months from the date of sale. This warranty covers defective parts and workmanship provided that the product is shipped prepaid to the seller within 24 months of purchase of goods. This warranty is limited to the repair or replacement (at the manufacturers' discretion) of parts and shipping prepaid to the original despatch destination. We regret that no liability can be accepted for consequential or special damages of any kind howsoever arising in connection with products supplied by the seller. This warranty is in lieu of all other warranties expressed or implied. No representative is authorised to assume for the seller any other liability in connection with the seller's products.