

Single level pressure switch Type 760

Description

The type 760 pressure switch consists of a moving diaphragm and disc which activate a changeover contact (snap action).

The contact can be calibrated to trip and reset at the desired pressure levels, as specified in fig. 6 (diagram A).

The main contact may also close a secondary creep action contact in series when it travels beyond the trip position (flood protection contact)..

The main contact may also have a safety "heating element protector" which allows resetting even if the contacts have welded on the trip side.

The terminals are arranged to accept a 12,5 mm pitch connector, or alternatively rast 5 (see fig. 4).

Applications

The main application is to control the level of water in appliances.

May also provide flood protection and heater protection.

Mechanical

Available with lateral spout, angular position as specified by customer (α), or with CENTRAL spout.

On the lateral spout version, the cap can have an integral clip for snap-in mounting. The mounting position must be indicated on the customer's drawing as it has an influence on calibration.

Mounting

The pressure switch may be snap-mounted onto a steel or plastic panel or using a bracket and 3,5x11 mm self-tapping screws.

Electrical characteristics

MAIN CONTACT

Max voltage: 250 VAC
Resistive load max: 16 A
Motor load max: 4 A

FLOOD PROTECTION CONTACT

Max voltage: 250 VAC
Resistive load max: 1 A
Motor load max: 1 A

HEATING ELEM. PROTECT. CONTACT

Max voltage: 250 VAC
Resistive load max: 0,1 A



Frequency: 50-60 Hz
Duty: Frequent
Contact clearance: μ (<3 mm)
Max pressure: 5.000 PA
Max ambient temp.: 85°C max
Dielectric strenght between terminals and support: >2,75 KV (1 min)

Resistance between terminals and support: >50 M Ω

The terminal housing is made from plastic resistant to GLOW-WIRE TEST at 850°C.

The product meets the requirements of EN 60335, EN 60730-2-6 (Safety of electrical appliances) and is approved by the principal European authorities: IMQ, VDE, UTE, SEMKO, DEMKO, NEMKO, FEMKO, KEMA KEUR, ASE/SEV, BEAB, OEVE.

The pressure switch can be supplied in a version which complies with UL and CSA requirements:

Max voltage: 125/250 V
50-60 Hz
Resistive load: 15/10 A

VERS. FOR ELECTRONIC CONTROLS

Max voltage: 5 V
Max resistive load: 5 mA

Panel mounting

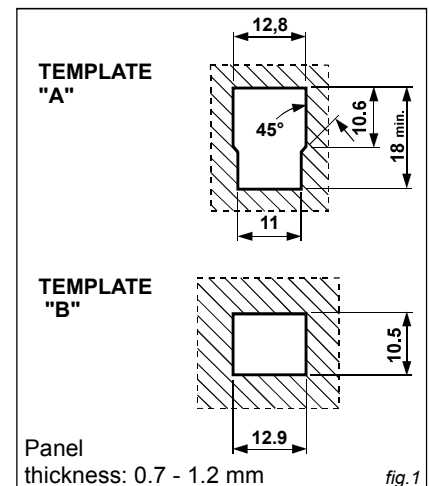

Removal of device from panel

With template "A", rotate the device through 90° and remove.

With template "B", close the two clips using pliers and remove.

Single level pressure switch
Type 760

Basic single level version

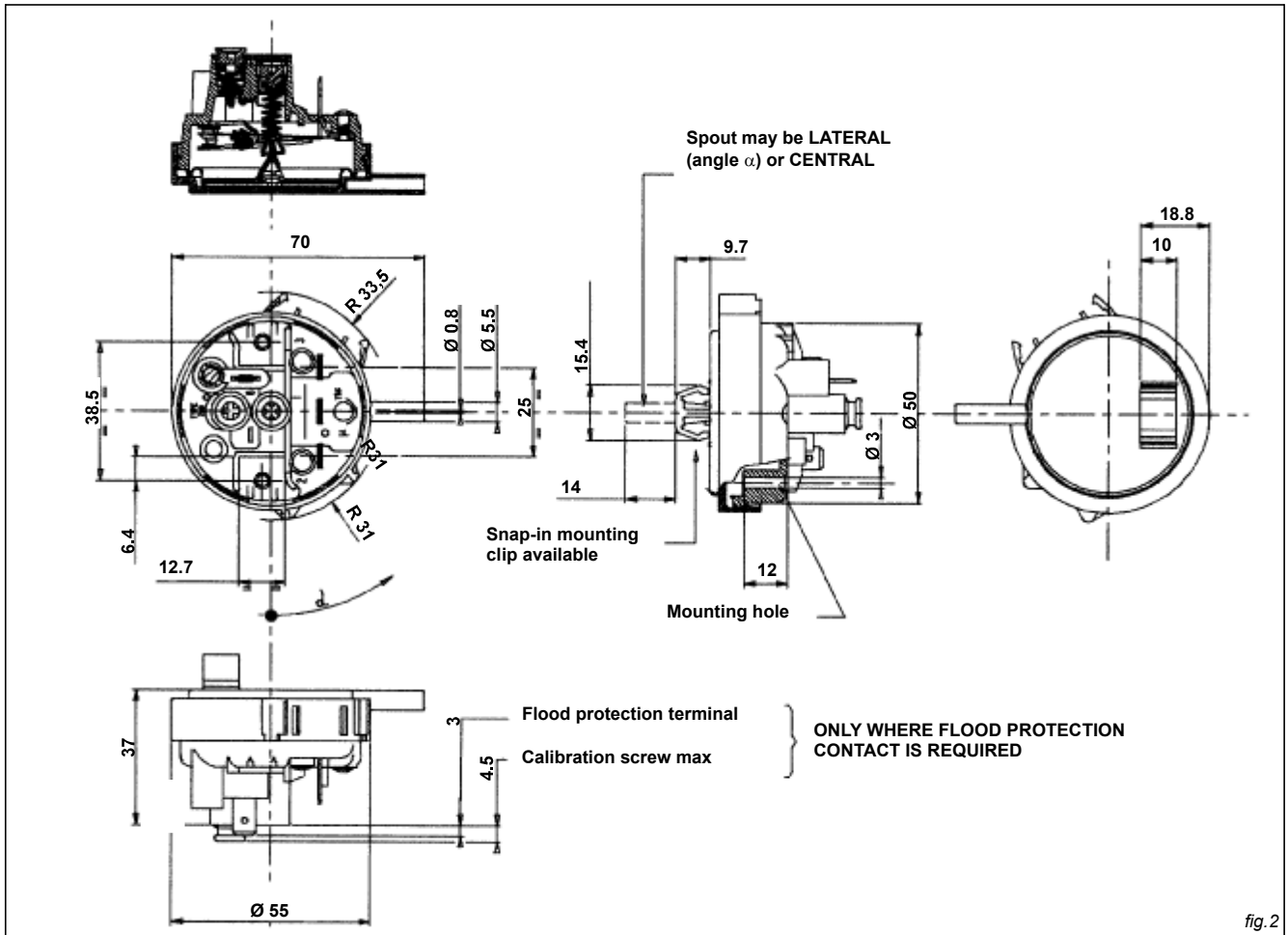

Two level version (dimensions)

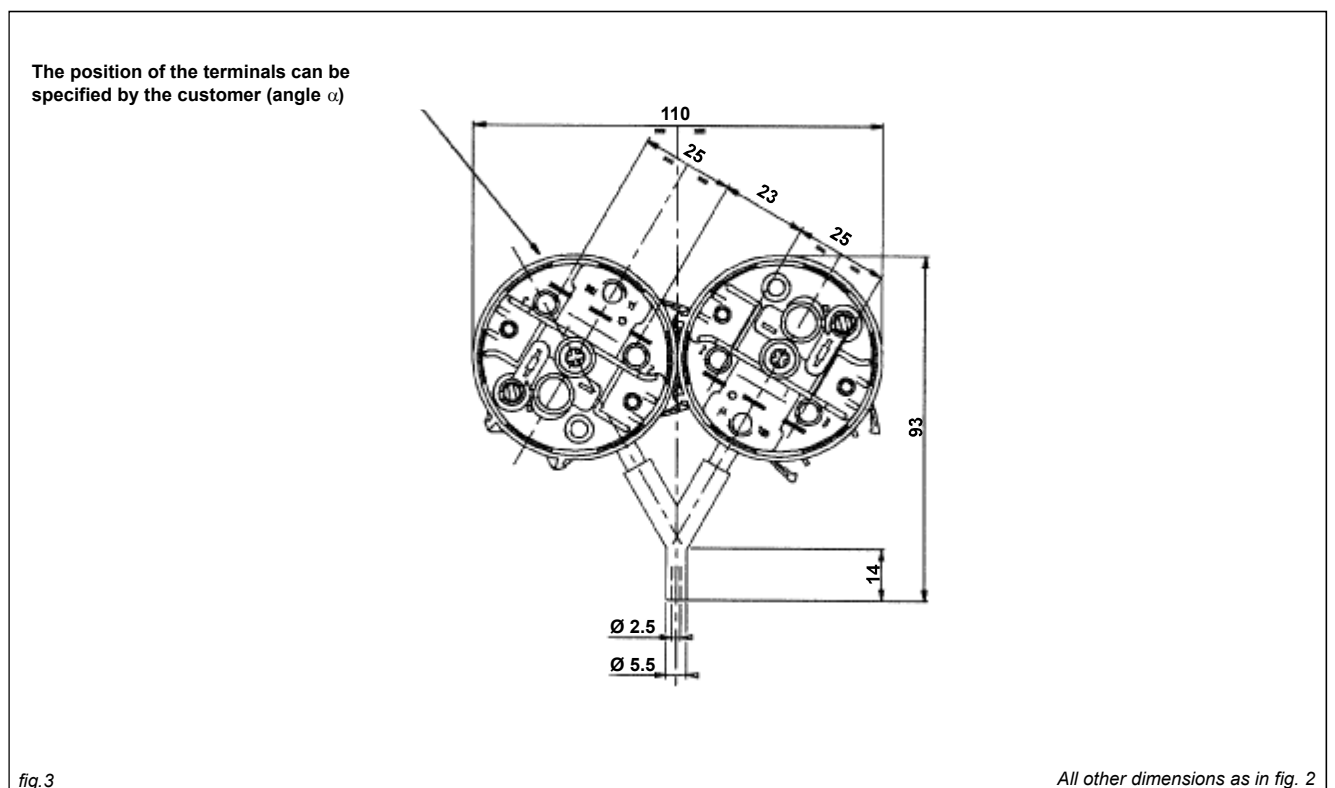

Single level pressure switch
Type 760

Rast 5 terminal version

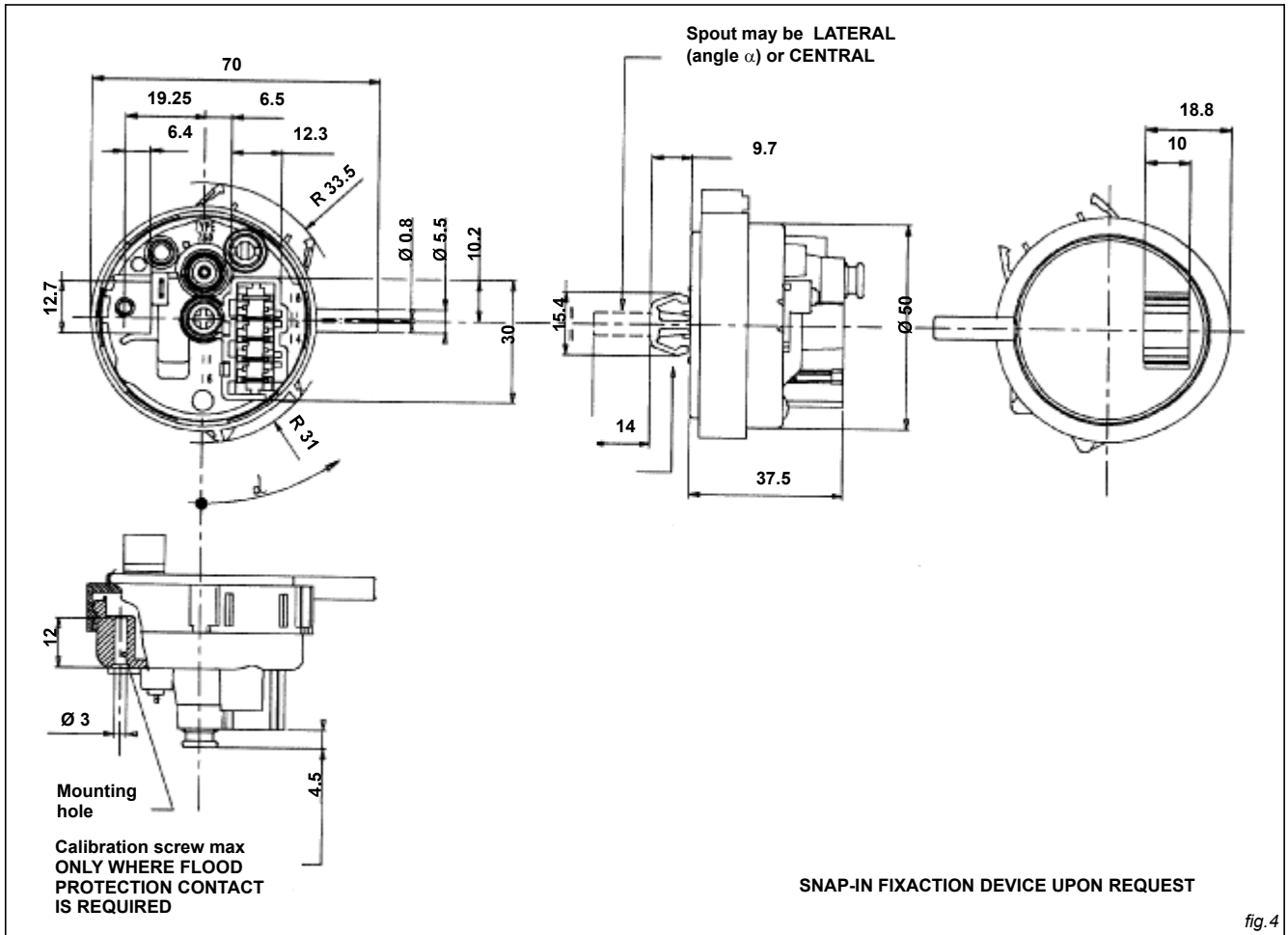

Terminal configurations

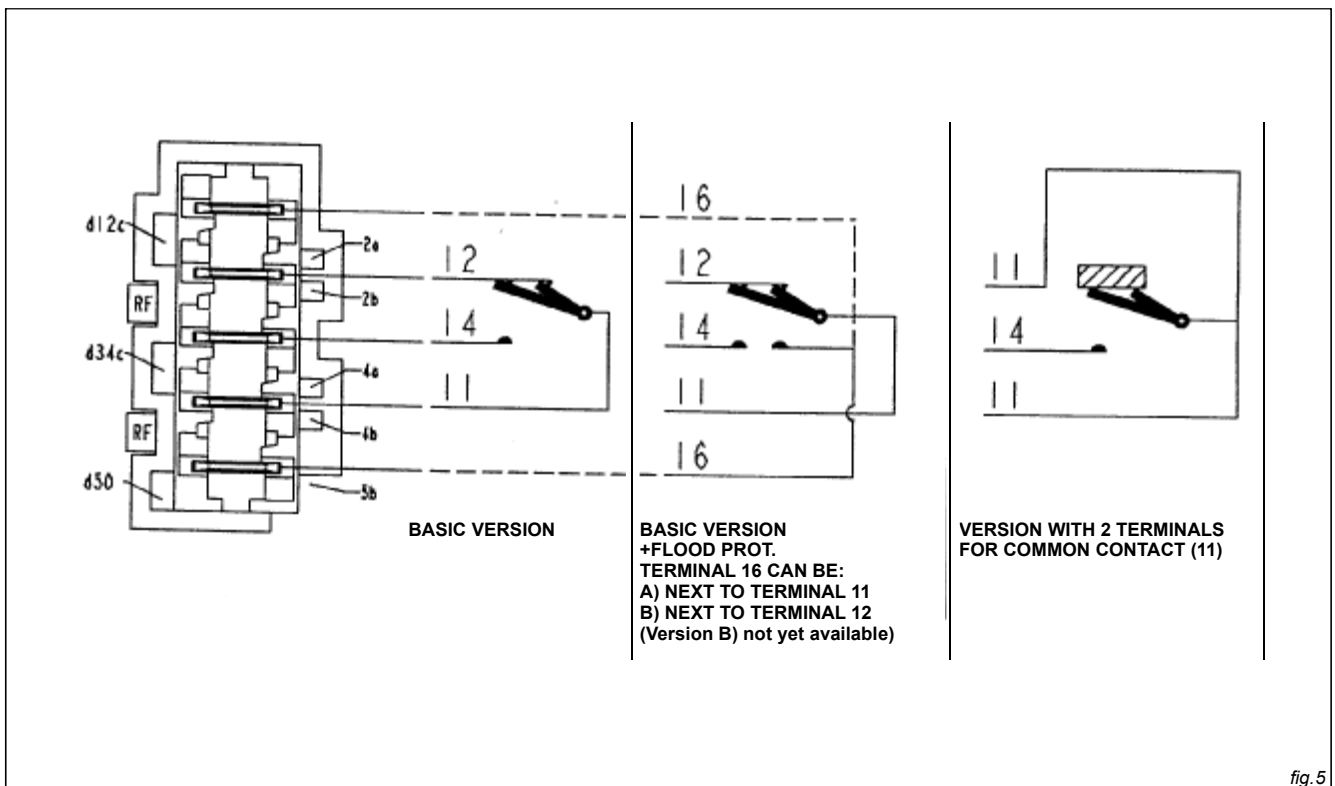

Single level pressure switch
Type 760

Diagram "A"

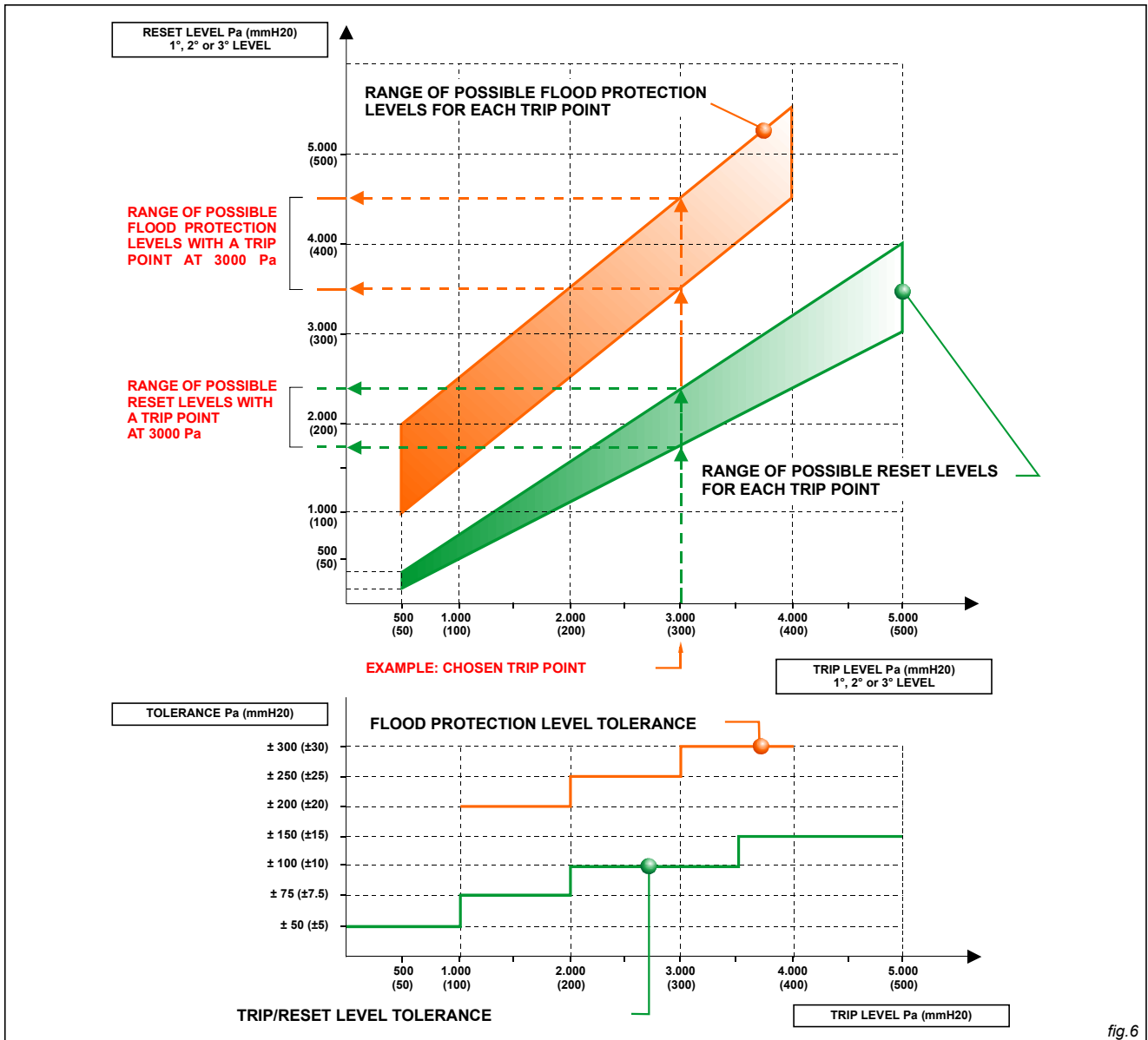

BITRON Industrie S.p.A. Marketing & Sales Activities

BITRON Ind. Marketing Deutschland
GmbH Elektrotechn. Vertrieb
Bismarkstrasse, 11 - D-61169 Friedberg
Tel. (49) (6031) 60040.1/2
Fax (49) (6031) 600435

BITRON Ind. Marketing France
26 Avenue de la Chataigneraie
92500 Rueil Mailmaison
Tel. (33) (3) 55471680 -
Fax (33) (3) 47520659

BITRON Ind. Marketing España
Calle ifni 24-30
08930 San Adrián de Besós
Barcelona (España)
Tel. (34) (93) 4620159 Fax (34) (93) 4620283

BITRON Industrie S.p.A.
Appliance Division:
Via De Amicis, 78
10097 Borgata Paradiso - Collegno (TO)
Tel. (39) (011) 4102.570
Fax. (39) (011) 4102.585

Automotive Division:
Strada del Portone, 95
10095 Grugliasco (TO)
Tel. (39) (011) 4029.111
Fax. (39) (011) 4029519

BITRON Ind. Marketing Latinamerica
Estrada Aldeia da Serra, 711 Itaquí
06696-050 Itapevi
São Paulo (SP) - Brasil
Tel. (55) (11) 47898250
Fax (55) (11) 47898255

BITRON Ind. Marketing USA
Automotive
Tel. (001) (248) 960.6427
Fax (001) (248) 960.6455
Appliance
Tel. (001) (317) 842.8583
Fax (001) (317) 842.8547