













### Economical, Subminiature Basic Switch Offers Long Life (30 x 10<sup>6</sup> Operations)

- Incorporating simple and stable two split springs which ensures a long service life (30,000,000 operations).
- A variety of models with low operating force to high operating force are available.
- Solder, quick-connect (#110) and PCB terminals are available.
- Models with a switching current of 10.1 A incorporate special contacts made of silver alloy that are tough and highly conductive.



## Ordering Information

Consult OMRON for standard approvals of models.

Rating	Actuator	OF max.	Soldering terminal	Quick-connect terminal (#110)	PCB terminal
0.1 A (bifurcated crossbar contacts for microvoltage/current load)	Pin plunger 	25 g	SS-01-E	SS-01-ET	SS-01-ED
		50 g	SS-01-F	SS-01-FT	SS-01-FD
		150 g	SS-01	SS-01-T	SS-01D
	Hinge lever 	8 g	SS-01GL-E	SS-01GL-ET	SS-01GL-ED
		16 g	SS-01GL-F	SS-01GL-FT	SS-01GL-FD
		50 g	SS-01GL	SS-01GLT	SS-01GLD
	Simulated hinge lever 	8 g	SS-01GL13-E	SS-01GL13-ET	SS-01GL13-ED
		16 g	SS-01GL13-F	SS-01GL13-FT	SS-01GL13-FD
		50 g	SS-01GL13	SS-01GL13T	SS-01GL13D
	Hinge roller lever 	8 g	SS-01GL2-E	SS-01GL2-ET	SS-01GL2-ED
		16 g	SS-01GL2-F	SS-01GL2-FT	SS-01GL2-FD
		50 g	SS-01GL2	SS-01GL2T	SS-01GL2D
5 A (standard rivet contact)	Pin plunger 	50 g	SS-5-F (see note)	SS-5-FT	SS-5-FD (see note)
		150 g	SS-5 (see note)	SS-5T	SS-5D (see note)
	Hinge lever 	16 g	SS-5GL-F (see note)	SS-5GL-FT	SS-5GL-FD (see note)
		50 g	SS-5GL (see note)	SS-5GLT	SS-5GLD (see note)
	Simulated hinge lever 	16 g	SS-5GL13-F (see note)	SS-5GL13-FT	SS-5GL13-FD (see note)
		50 g	SS-5GL13 (see note)	SS-5GL13T	SS-5GL13D (see note)
	Hinge roller lever 	16 g	SS-5GL2-F (see note)	SS-5GL2-FT	SS-5GL2-FD (see note)
		50 g	SS-5GL2 (see note)	SS-5GL2T	SS-5GL2D (see note)
10.1 A (standard rivet contact)	Pin plunger 	150 g	SS-10 (see note)	SS-10T	SS-10D (see note)
	Hinge lever 	50 g	SS-10GL (see note)	SS-10GLT	SS-10GLD (see note)
	Simulated hinge lever 	50 g	SS-10GL13 (see note)	SS-10GL13T	SS-10GL13D (see note)
	Hinge roller lever 	50 g	SS-10GL2 (see note)	SS-10GL2T	SS-10GL2D (see note)

Note: EN61058-1 (IEC1058-1) approved by TÜV Rheinland.

## ■ Model Number Legend

SS-□□□□  
1 2 3 4

### 1. Ratings

01: 0.1 A  
5: 5 A  
10: 10 A

### 2. Actuator

None: Pin plunger  
GL: Hinge lever  
GL13: Simulated hinge lever  
GL2: Hinge roller lever

### 3. OF Max. (at Pin Plunger)

None: 150 gf  
-F: 50 gf  
-E: 25 gf

### 4. Terminals

None: Solder  
T: Quick-connect (#110)  
D: PCB

## Specifications

### ■ Ratings

Type	Rated voltage	SS-10, SS-5								SS-01	
		Non-inductive load				Inductive load				Non-inductive load	
		Resistive load		Lamp load		Inductive load		Motor load		Resistive load	
		NC	NO	NC	NO	NC	NO	NC	NO	NC	NO
General-purpose	125 VAC	5 (10.1) A		1.5 A	0.7 A	3 A		2.5 A	1.3 A	0.1 A	
	250 VAC	3 (10.1) A		1 A	0.5 A	2 A		1.5 A	0.8 A	---	
	8 VDC	5 (10.1) A		2 A		5 A	4 A	3 A		---	
	14 VDC	5 (10.1) A		2 A		4 A	4 A	3 A		---	
	30 VDC	4 A		2 A		3 A	3 A	3 A		0.1 A	
	125 VDC	0.4 A		0.05 A		0.4 A	0.4 A	0.05 A		---	
	250 VDC	0.2 A		0.03 A		0.2 A	0.2 A	0.03 A		---	

- Note:**
1. Inductive load has a power factor of 0.4 min. (AC) and a time constant of 7 ms max. (DC).
  2. Lamp load has an inrush current of 10 times the steady-state current.
  3. Motor load has an inrush current of 6 times the steady-state current.
  4. Data in parentheses apply to the SS-10 series only.
  5. If the switch is used in a DC circuit and is subjected to a surge, connect a surge suppressor across the switch.

### Contact Form

The normally open (SPST-NO) and normally closed (SPST-NC) types are not listed under *Ordering Information*. Consult OMRON directly.

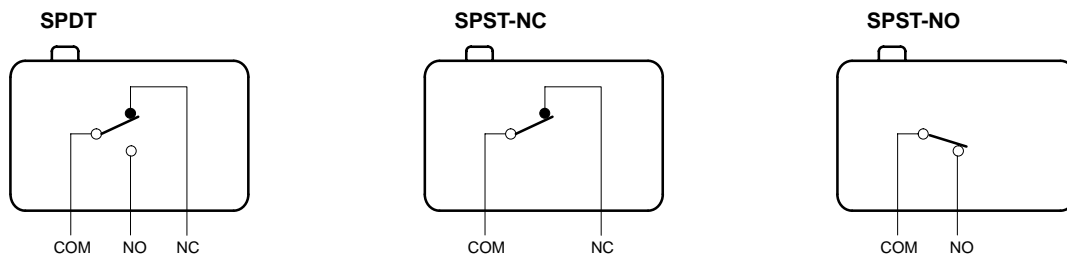

### ■ Approved Standards

**UL (File No. E32667)/CSA (File No. LR21642)**

SS-10 series: 10.1 A at 250 VAC  
SS-5 series: 5 A at 125 VAC, 3 A at 250 VAC  
SS-01 series: 0.1 A at 125 VAC, 0.1 A at 30 VDC

**SEMKO (File No. 8614026)/VDE (File No. 221)**

SS-5 series: 5 A at 250 VAC

**SEMKO (File No. 8916091)/VDE (File No. 221)**

SS-10 series: 10 A at 250 VAC

**SEV (File No. 93, 5, 51936, 01)**

SS-5 series: 5 A at 250 VAC

**EN61058-1 (IEC1058-1) (TÜV Rheinland, File No. T9451450)**

SS-5: 5 A at 250 VAC, 5(1) A at 250 VAC

SS-10: 10 A at 250 VAC

## ■ Characteristics

<b>Operating speed</b>	0.1 mm to 1 m/s (at pin plunger)
<b>Operating frequency</b>	Mechanical: 400 operations/min Electrical: 60 operations/min
<b>Insulation resistance</b>	100 MΩ min. (at 500 VDC)
<b>Contact resistance (initial value)</b>	OF 150 gf: SS-01 series: 50 mΩ max. SS-5, SS-10 series: 30 mΩ max.  OF 50 gf: SS-01 series: 100 mΩ max. SS-5 series: 50 mΩ max.  OF 25 gf: SS-01 series: 150 mΩ max.
<b>Inrush current</b>	NC: 20 A max. for SS-10 and SS-5, 1 A max. for SS-01 NO: 15 A max. for SS-10, 10 A max. for SS-5, 1 A max. for SS-01
<b>Dielectric strength</b>	1,000 VAC (600 VAC for crossbar contact model), 50/60 Hz for 1 min between the same polarities 1,500 VAC, 50/60 Hz for 1 min between current-carrying metal part and ground, and between each terminal and non-current-carrying metal part
<b>Vibration resistance</b>	Malfunction: 10 to 55 Hz, 1.5-mm double amplitude
<b>Shock resistance</b>	Mechanical: OF 150 gf: 1,000 m/s <sup>2</sup> (approx. 100G min.) OF 25/50 gf: 500 m/s <sup>2</sup> (approx. 50G min.) Malfunction: OF 150 gf: 300 m/s <sup>2</sup> (approx. 30G min.) OF 25/50 gf: 200 m/s <sup>2</sup> min. (approx. 20G min.) <b>Note:</b> Lever-type model: Operating limit position (with a contact separation time of 1 ms max.)
<b>Life expectancy</b>	Mechanical: 30,000,000 operations min. (OT: rated value) 10,000,000 operations min. for SS-10 series Electrical: 200,000 operations min. (OT: full) 50,000 operations min. for SS-10 series
<b>Ambient temperature</b>	Operating: -25°C to 85°C (with no icing)
<b>Ambient humidity</b>	Operating: 85% max.
<b>Contact</b>	Type: Rivet for SS-10 and SS-5, crossbar for SS-01 Material: Silver alloy for SS-10, silver for SS-5, PGS alloy for SS-01
<b>Weight</b>	Approx. 1.6 g (pin plunger)

## Characteristics Approved by TÜV Rheinland for EN61058-1

<b>Enclosure rating</b>	IP00
<b>Degree of protection against electrical shock</b>	Class 1
<b>Ambient temperature</b>	0°C to 85°C (with no icing)
<b>Operating cycles</b>	50,000
<b>Proof Tracking Index (PTI)</b>	175 V
<b>Switch category</b>	D

## ■ Operating Characteristics

Model	SS-01-E	SS-01-F, SS-5-F	SS-01, SS-5	SS-10
<b>OF max.</b>	0.25 N (25 gf)	0.49 N (50 gf)	1.47 N (150 gf)	1.47 N (150 gf)
<b>RF min.</b>	0.02 N (2 gf)	0.04 N (4 gf)	0.25 N (25 gf)	0.25 N (25 gf)
<b>PT max.</b>	0.5 mm	0.5 mm	0.5 mm	0.6 mm
<b>OT min.</b>	0.5 mm	0.5 mm	0.5 mm	0.4 mm
<b>MD max.</b>	0.1 mm	0.1 mm	0.1 mm	0.12 mm
<b>OP</b>	8.4±0.5 mm			

Model	SS-01GL-E	SS-01GL-F, SS-5GL-F	SS-01GL, SS-5GL	SS-10GL
<b>OF max.</b>	0.08 N (8 gf)	0.16 N (16 gf)	0.49 N (50 gf)	0.49 N (50 gf)
<b>RF min.</b>	(0.01 N (1 gf))	0.02 N (2 gf)	0.06 N (6 gf)	0.06 N (6 gf)
<b>OT min.</b>	1.2 mm	1.2 mm	1.2 mm	1.0 mm
<b>MD max.</b>	0.8 mm	0.8 mm	0.8 mm	1.0 mm
<b>FP max.</b>	13.6 mm			
<b>OP</b>	8.8±0.8 mm			

**Note:** Values in brackets are possible when the switch is mounted so that the weight of the lever will not be imposed on the plunger.

Model	SS-01GL13-E	SS-01GL13-F, SS-5GL13-F	SS-01GL13, SS-5GL13	SS-10GL13
OF max.	0.08 N (8 gf)	0.16 N (16 gf)	0.49 N (50 gf)	0.49 N (50 gf)
RF min.	(0.01 N (1 gf))	0.02 N (2 gf)	0.06 N (6 gf)	0.06 N (6 gf)
OT min.	1.2 mm	1.2 mm	1.2 mm	1.0 mm
MD max.	0.8 mm	0.8 mm	0.8 mm	1.0 mm
FP max.	15.5 mm			
OP	10.7±0.8 mm			

Model	SS-01GL2-E	SS-01GL2-F, SS-5GL2-F	SS-01GL2, SS-5GL2	SS-10GL2
OF max.	0.08 N (8 gf)	0.16 N (16 gf)	0.49 N (50 gf)	0.49 N (50 gf)
RF min.	(0.01 N (1 gf))	0.02 N (2 gf)	0.06 N (6 gf)	0.06 N (6 gf)
OT min.	1.2 mm	1.2 mm	1.2 mm	1.0 mm
MD max.	0.8 mm	0.8 mm	0.8 mm	1.0 mm
FP max.	19.3 mm			
OP	14.5±0.8 mm			

**Note:** Values in brackets are possible when the switch is mounted so that the weight of the lever will not be imposed on the plunger.

## Engineering Data

### Mechanical Life Expectancy

SS-5, SS-01 Series

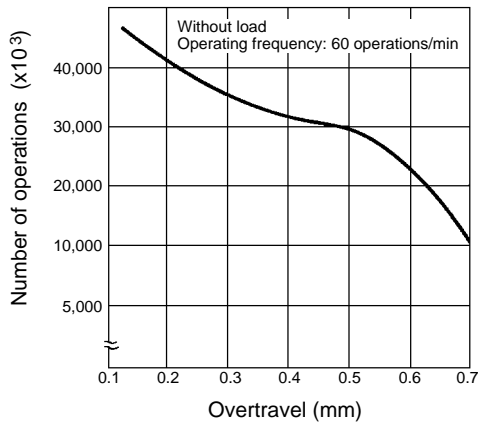

### Electrical Life Expectancy

SS-5 Series

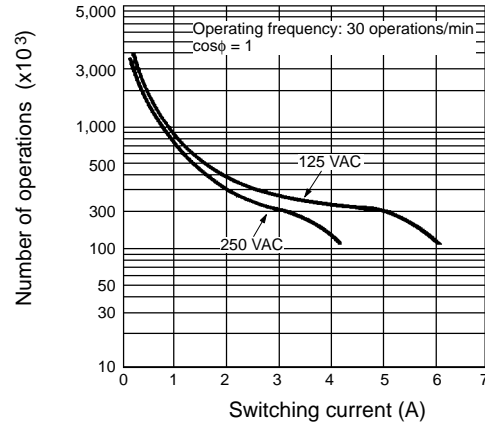

# Dimensions

- Note:**
1. All units are in millimeters unless otherwise indicated.
  2. Unless otherwise specified, a tolerance of  $\pm 0.4$  mm applies to all dimensions.
  3. The following illustration and drawing are for solder terminal models. Refer to page 94 for details on models with quick-connect terminals (#110) or PCB terminals.

## Pin Plunger

SS-01(-E, -F)  
SS-5(-F)  
SS-10

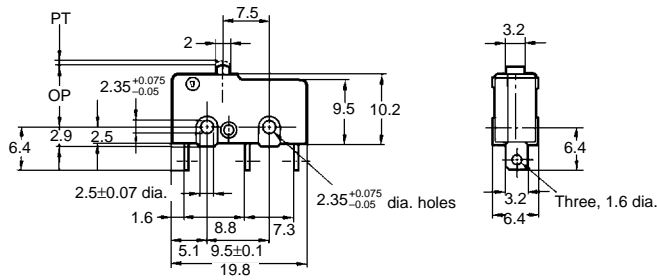
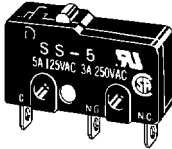

## Hinge Lever

SS-01GL(-E, -F)  
SS-5GL(-F)  
SS-10GL

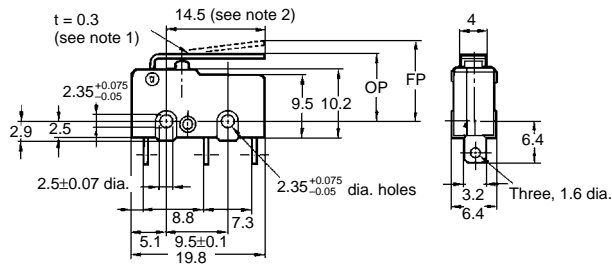
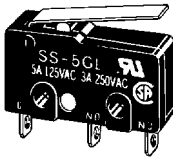

- Note:**
1. Stainless steel lever
  2. Besides the SS-□GL-series models with a hinge lever length of 14.5, the SS-□GL11-series models with a hinge lever length of 18.5, the SS-□GL111-series models with a hinge lever length of 22.6, and the SS-□GL1111-series models with a hinge lever length of 37.8 are available. Contact your OMRON representative for these models

## Simulated Hinge Lever

SS-01GL13(-E, -F)  
SS-5GL13(-F)  
SS-10GL13

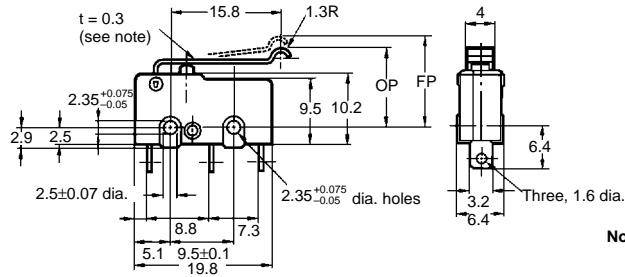
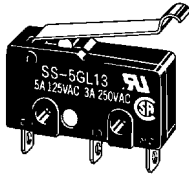

**Note:** Stainless steel spring lever

## Hinge Lever

SS-01GL2(-E, -F)  
SS-5GL2(-F)  
SS-10GL2

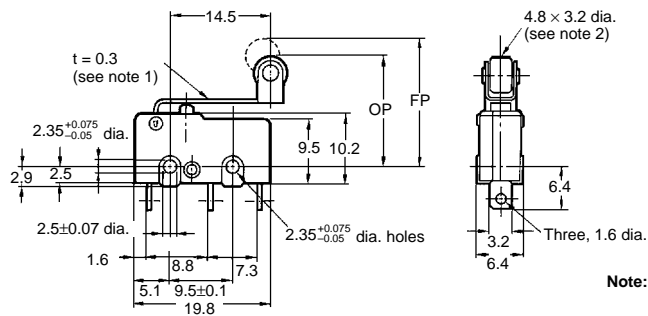

- Note:**
1. Stainless steel spring lever
  2. Polyacetal resin roller

■ Terminals

Solder Terminal

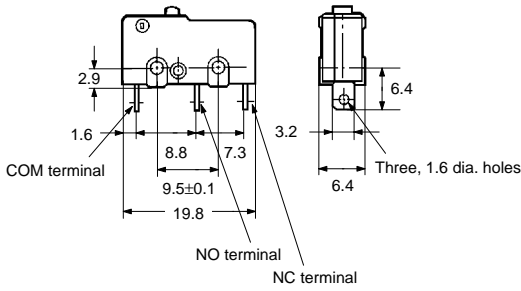

Quick-connect Terminal (#110)

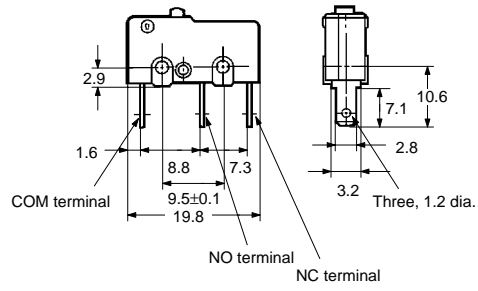

PCB Terminal

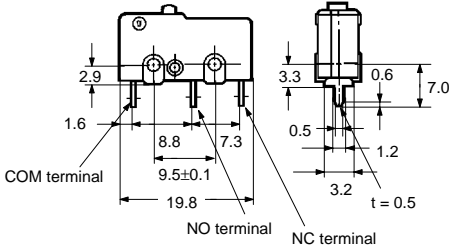

PCB Mounting Dimensions (Reference)

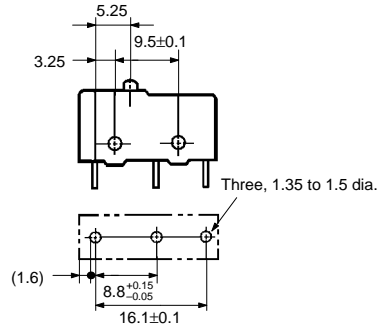

Precautions

Mounting

Use two M2.3 mounting screws with spring washers to mount the switch. Tighten the screws to a torque of 0.23 to 0.27 N • m (2.3 to 2.7 kgf • cm).

Mounting Holes

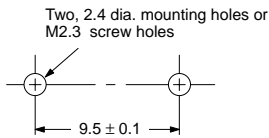

Actuating

For the secure operation, 60% to 90% of rated overtravel should be maintained.

Spacing

Switch does not have a ground terminal. The minimum thickness of insulation according to IEC1058-1 is 1.1 mm, and the minimum clearance between live terminals and mounting plate is 1.6 mm. If the proper insulation for the terminator cannot be obtained, add insulation such as a separator or insulation cover on the switch.

Soldering

When soldering switch terminals, apply a soldering iron rated at 60 W max. and finish soldering quickly within 5 seconds. During soldering and 1 minute after soldering, do not apply external force to the terminals. Solder terminals are provided with a hole for the mechanical mounting of a conductor. Conductors for the soldering terminal should be flexible and its cross-section should be 0.5 to 0.75 mm<sup>2</sup> for the SS-5 series and 0.75 mm<sup>2</sup> for the SS-10 series.

Others

If a surge current or inrush current is involved in a DC circuit, it is recommended to use a cancellation circuit.

**ALL DIMENSIONS SHOWN ARE IN MILLIMETERS.**  
To convert millimeters into inches, multiply by 0.03937. To convert grams into ounces, multiply by 0.03527.