

PART NO. NYLON	PART NO. FLAME RETARDANT NYLON	"A"	"B"	"H"
WWS-A-2-01	WWS-A-2-19	.77 (19.6)	.50 (12.7)	.64 (16.3)
WWS-A-3-01	WWS-A-3-19	1.12 (28.5)	.85 (21.6)	.99 (25.2)

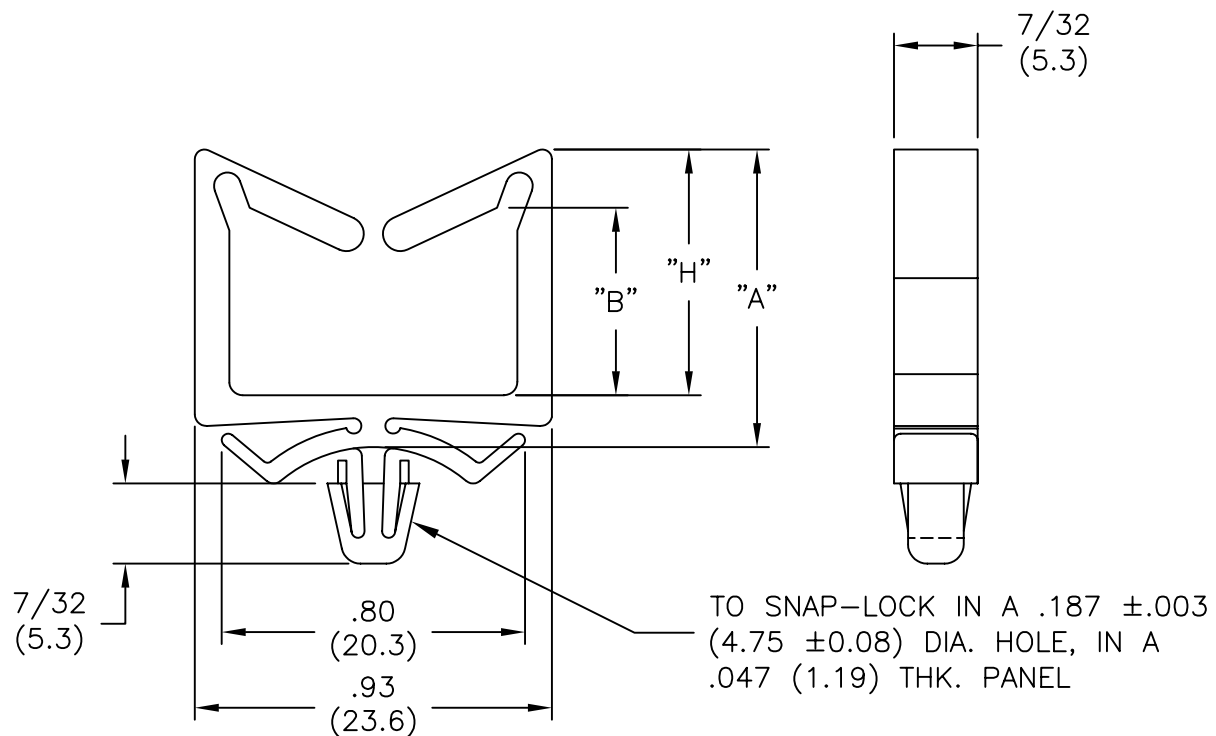

NOTES:
 1. MAT'L: NYLON 66 (RMS-01), NAT.
 AVAILABLE IN FLAME RETARDANT NYLON
 (RMS-19) BY SPECIAL ORDER

B	CHANGED FILE NO. AND TITLE BLOCK	SM 05.30.01
A	ADDED HOLE DIA. & PANEL THICKNESS	DD 5-8-96
REV	DESCRIPTION	ENGR DATE

TITLE: WIDE WIRE SADDLE		DWG IN IN (MM) FINAL			
TOLERANCES UNLESS NOTED .XX=±.010 .XXX=±.005 FRAC=±1/64 ANG=±1°	FILE # WWS	DWN: P.B.	APP:	PART #	
	MAT'L: SEE NOTES	DT: 08-18-94	DT:	SEE TABLE	
	RE: RICHCO, INC.	RICHCO INC. PO BOX 804238, CHICAGO, 60680 (773) 539-4060		PRINT TYPE CA	